



HBM 320 L-802M Military Airport Rotating Beacon



Compliance with Standards:

FAA: L-802M A/C 150/5345-12 (Current Edition)

Applications:

L-802M Rotating Beacons are designed for operation as identification and location markers for military airports.



Beacon Tipdown Pole

Features:



- Patented belt-drive system eliminates the lubrication maintenance required by conventional gear-drive beacons (U.S. Pat. 5,339,224)
- Patented liquid-filled lamp connector, eliminating the slip rings and brushes found on conventional beacons (U.S. Pat. 5,816,678)
- Two 34,000 lumen, 320 watt pulse-start metal-halide lamps
- Pulse-start lamps are fully bright in 3-5 minutes
- 20,000+ hour typical lamp life (4-5 years)
- One white dual-beam lens, one aviation green lens
- NO maintenance except lamp replacement
- All moving parts are permanently lubricated
- Thermally-protected motor eliminates burnouts
- Lamps preset 5° above horizontal, adjustable 2-10°
- 6 RPM rotation, 18 flashes/minute
- Weatherproof steel cabinet, powder coated international orange
- Optional stainless steel cabinet & bearings for highly corrosive environments
- Class I temperature range: -30 to +55 °C (-22 to +131 °F)
- Class II temperature range: -55 to +55 °C (-67 to +131 °F)
- Certified to wind velocities of 100 mph
- Can operate with photocell and/or tell-tale relay
- Mountable on a Hali-Brite Tipdown Pole
- Power Consumption: 793 W Class I, 1193 W Class II
- Manufactured in the USA

Sales and Technical Support:

1.800.553.6269

Sales@halibrite.com

 Hali-Brite, Inc.
1119 Madison Street
Brainerd, MN 56401

 www.halibrite.com
 Ph: 218.454.0956
 Fax: 218.454.0972

Ordering Information

Part Number	Description
L802M6116	120 VAC, 60 Hz, Class 1
L802M6126	220-240 VAC, 60 Hz, Class 1
L802M6216	120 VAC, 60 Hz, Class 2
L802M6226	220-240 VAC, 60 Hz, Class 2

NOTE: 220-240 VAC must be single wire with neutral

Options

Part Number	Description
L801/802 T/T HBM 120	Tell-tale Relay, 120 VAC
L801/802 T/T HBM 240	Tell-tale Relay, 220-240 VAC
4200-0000	Tower Mounting Kit
L801/L802 HBM SS	Stainless Steel Option

Replacement Parts

Part Number	Description
0200-0027	Ballast Assembly, 60 Hz
0600-0004	Belt
2300-0003	Lamp fuse, 10 amp
2300-0002	Motor fuse, 1/2 amp
3400-0136	Lamp, 320 watt pulse-start
2800-0056	Lens, aviation white
2800-0057	Lens, aviation green
0100-3825	Lens clip

Shipping Information

Unpackaged Weight: 155 pounds

USA Shipping Weight: 250 pounds

USA Shipping Volume: 48"x40"x33"

International Shipping Weight: 250 pounds

International Shipping Volume: 48"x40"x33"

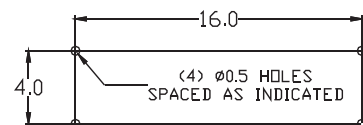
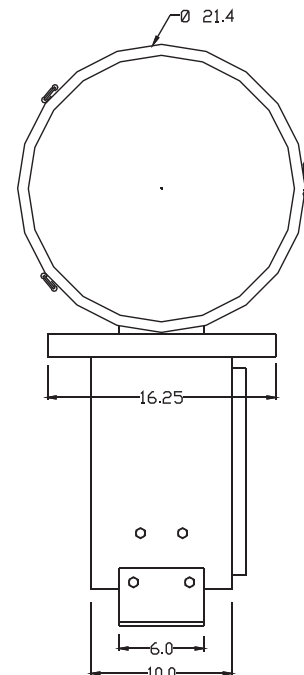
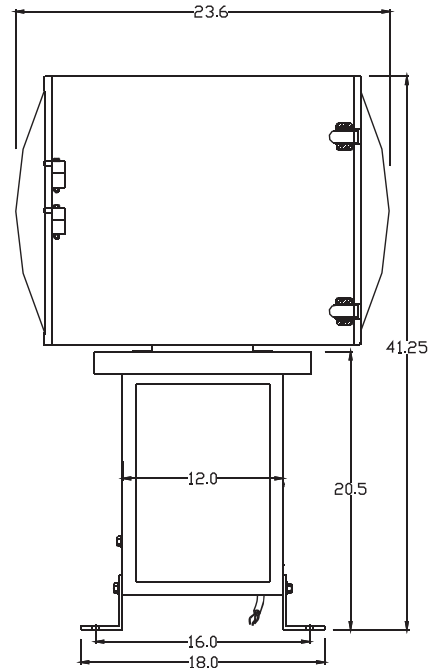

MOUNTING BOLT PATTERN

Sales and Technical Support:

1.800.553.6269
Sales@halibrite.com

Hali-Brite, Inc.
1119 Madison Street
Brainerd, MN 56401

www.halibrite.com
Ph: 218.454.0956
Fax: 218.454.0972