



# Hali-Brite®

## Hali-Brite® L802A 36" Refurbished Airport Rotating Beacon

### Applications

L-802A Rotating Beacons are designed primarily for night operation as identification and location markers for airports.

### Features

- Patented stationary lamp system eliminates the gear lubrication maintenance required by conventional gear-drive beacons (U.S. Pat. 5,339,224)
- Qualifies for AIP funding
- Available for exchange or direct purchase
- 36,000 lumen, 400 watt metal-halide lamp
- 20,000 hour typical lamp life (3-4 years)
- One clear lens, one aviation green lens
- Thermally-protected motor eliminates burnouts
- Lamp preset 5° above horizontal, adjustable
- 12 RPM rotation, 24 flashes/minute
- All new stainless steel fasteners
- Plated steel parts
- All new Teflon-coated wire
- Weatherproof aluminum housing, powder coated international orange
- Winterization option available for cold climates
- Optional photocell and/or tell-tale relay
- Warranty 2 years on parts, 1 year on labor (excludes lamps)
- Power Consumption: 635W, 1035W with winterization option
- Manufactured in the USA



### Sales and Technical Support:

1.800.553.6269

[Sales@halibrite.com](mailto:Sales@halibrite.com)

📍 Hali-Brite, Inc.  
1119 Madison Street  
Brainerd, MN 56401

🌐 [www.halibrite.com](http://www.halibrite.com)  
☎ Ph: 218.454.0956  
📠 Fax: 218.454.0972



# Hali-Brite®

## Ordering Information

### Part Number

### Description

L802A1116BSE 120 VAC, 60 Hz, Standard Base, Customer Exchange  
L802A1116BSS 120 VAC, 60 Hz, Standard Base, No Exchange

L802A1216BSE 120 VAC, 60 Hz, Standard Base, Customer Exchange, with Heater Option  
L802A1216BSS 120 VAC, 60 Hz, Standard Base, No Exchange

*NOTE: 220-240 VAC available, contact Factory*

### Part Number

### Description

L802 T/T DCB 36 Tell-tale Relay, 120 VAC

## Replacement Parts

### Part Number

### Description

0200-0005 Ballast  
0600-0001 Belt  
2300-0005 Fuse, 10 amp  
3400-0400U Lamp, 400 watt  
2800-0001 Lens, Left Outer Sector  
2800-0002 Lens, Right Outer Sector  
2800-0003 Lens, Outer Bullseye  
2800-0033 Lens, Inner Clear  
2800-0011 Lens, Inner Green

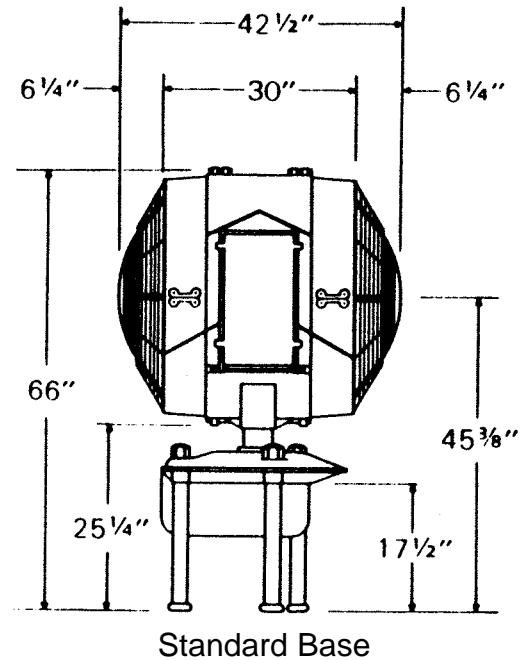

## Shipping Information



Unpackaged Weight: 450 pounds  
Shipping Weight: 950 pounds  
Shipping Volume: 48"x48"x77"

### Sales and Technical Support:

1.800.553.6269

Sales@halibrite.com

 Hali-Brite, Inc.  
1119 Madison Street  
Brainerd, MN 56401

 [www.halibrite.com](http://www.halibrite.com)  
 Ph: 218.454.0956  
 Fax: 218.454.0972



# Hali-Brite®