

# Vigilant® LED Marker

## Low Intensity (Red)



### Certifications & Ratings

- 5 year warranty
- FAA AC 150/5345-43H
- FAA AC 70/7460-1L
- FAA Engineering Brief 67D
- ICAO Annex 14
- Transport Canada CAR 621.19
- CE

### Single Fixture

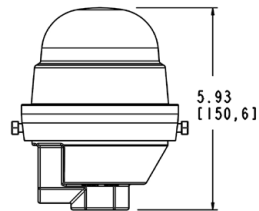
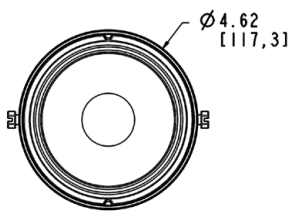

Dimensions in inches [mm]

### Dual Fixture

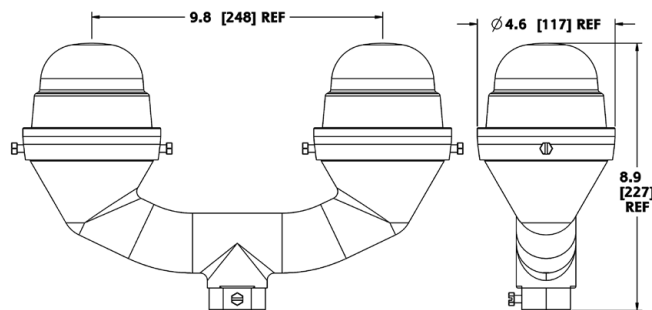

Dimensions in inches [mm]

## FAA L-810 / ICAO Low Type B+E

### Mechanical Information:

<b>Weight:</b>	Single unit - 2.00 lbs (0.91 kg) Dual unit - 4.60 lbs (2.09 kg)
<b>Mounting Details:</b>	NPT 3/4" and 1" NPT
<b>Impact Rating:</b>	IK10
<b>Protection Rating:</b>	IP66
<b>Included Hardware:</b>	1" NPT plug
<b>Cable Entry Size:</b>	NPT 3/4" and 1" NPT
<b>Aerodynamic Wind Area:</b>	0.15 ft <sup>2</sup>

### Electrical Specifications:

**Operating Temperature:** -40°F to +131°F (-40°C to +55°C)

**Power Factor:** > 0.9

### Power Consumption:

#### Standard

**Single & Dual Units -** 1.5W nominal (DC version)  
6.5W nominal (AC version)

#### IR Models

**Single & Dual Units -** 5.0 W (DC version)  
5.5 W (AC version)

**Input Current:** 120-240 VAC, 50/60 Hz (55mA nominal)  
12-48 VDC (63mA nominal)

### Photometric Information:

#### Flash Intensity (nominal):

**Night (Red):** 32 cd  
**IR Wavelength:** peak @ 850nm

#### Flash Rate:\*

**Night (Red)** 20/30/40 flashes per min  
**IR Pulse Rate** 20/30/40 flashes per min

**Expected Lamp Life** 100,000 hours (approx. 10 years)

\*Can also operate as steady burn

All values typical unless otherwise stated (tolerance +/- 10%)