



Hali-Brite® RCM-D L-893(L) Runway Closure Marker



Compliance with Standards:

ETL Certified to FAA AC 150/5345-55 latest revision, Engineering Brief 67, with FAA AC 150/5370-2 and NTSB Safety Recommendation A-03-05

Applications:

• The Hali-Brite® Runway Closure Marker is an effective method to warn pilots of closed runways and taxiways



Features:

- Easily set up by one person in less than 5 minutes, without tools
- 3 year/3000 hour engine warranty
- Four folding arms open to 14 foot length
- 20 LED lamps deliver over 70,000 candelas at beam center
- Visible 10-25 miles from runway under VFR
- Selectable brightness levels to suit environmental conditions
- Photocell dimming for night operation
- Four rear-mounted lamps allow visual monitoring from rear side
- Powered by a three-cylinder, liquid cooled Mitsubishi diesel engine and Marathon brushless generator
- Operates 140 hours between fuel fills
- Highway towable, with a standard 2" hitch coupler
- 2200 pound, DOT compliant trailer
- 4 swivel leveling jacks
- Adjustable light beam angle
- Optional rear hitch, allows tandem towing of 2 units
- Optional cover

Sales and Technical Support:

1.800.553.6269

Sales@halibrite.com

Set Up Procedure (5 minutes):



1. Level as necessary using 3 leveling jacks



2. Extend the 4 light assembly arms



3. Tilt the light to the upright position



4. Start the generator and activate the lights

Light Assembly Specifications:

- Arm length 14 feet when operating
- Hinged to generator housing, swings upright for use, swings to horizontal position when stowed
- Assembly arms fold to a 5'x5' square for transport and storage
- Arms constructed of 4"x4" extruded aluminum, with yellow epoxy powder-coat paint.
- Twenty LED lamps mounted in front, plus 4 monitor lamps in rear, 24 total
- LED lamp, 20 degree beam width, rated life 50,000 hours typical
- Lamps flash 2.5 seconds on, 2.5 seconds off
- Solid-state flasher, no mechanical contacts
- Photocell automatically reduces intensity at night
- 2 year warranty on light assembly,
- 4 year warranty on lamps
- Maximum Power: 630 watts, 643VA at 120VAC

Trailer Specifications:

- 2200 pound axle
- 2" ball or optional pintle hitch, safety chains
- Four 2000 lb. leveling jacks. Side jacks are on extendable 38" outriggers
- DOT-compliant tail and marker lights
- Tires - ST175/80 D13, highway-rated
- All steel tubing construction
- Width: 67" Length: 105" Height: 64"
- Total wet weight 1600 lbs

Engine and Generator Specifications:

- Engine: Mitsubishi L3E Diesel, 12.7 hp, 3-cylinder, liquid-cooled, 4-stroke, 1800 RPM, electric start
- Engine Warranty: 2 years/2000 hours on entire engine, 3 years/3000 hours on major components
- Glow plugs and elapsed hour meter
- Low oil/high temperature auto-shutdown
- Generator: Marathon Electric, 6.0 kW, 120 VAC, 4-pole, brushless
- Fuel tank capacity 57 gal., consumption 0.4 gph, 140 hour runtime

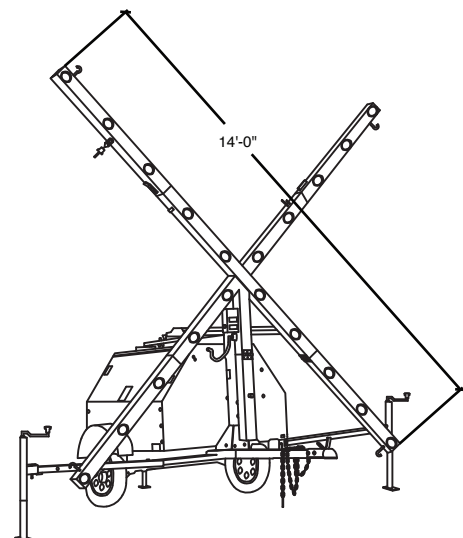

Sales and Technical Support:

1.800.553.6269

Sales@halibrite.com

📍 Hali-Brite, Inc.
 1119 Madison Street
 Brainerd, MN 56401

🌐 www.halibrite.com
 ☎ Ph: 218.454.0956
 📠 Fax: 218.454.0972