



Hali-Brite®

Installation and Maintenance Manual



HBM 150/2 L-801A Airport Rotating Beacon

Hali-Brite® Inc.
1119 Madison St
Brainerd, MN 56401
Tel: 800.553.6269
Fax: 218.454.0972
www.halibrite.com

Table of Contents

1	Introduction.....	3
1.1	About this Manual.....	3
1.2	Model Configurations	3
1.3	Warranty	3
1.4	Disclaimers	4
2	Safety Precautions.....	5
2.1	Safety Statements.....	5
2.2	General Practices	5
2.3	Electrical Practices.....	6
2.4	Qualified Personnel.....	7
2.5	Proper Usage.....	7
3	Specifications	8
3.1	Electrical and Optical Specifications	8
3.2	Physical Specifications	8
3.3	Environmental Specifications	8
4	Installation.....	9
4.1	Unpacking.....	9
4.2	Tools and Supplies Needed.....	9
4.3	Installation.....	9
5	Maintenance	12
5.1	Maintenance Schedule	12
5.2	Maintenance Procedures	12
6	Repair.....	14
6.1	Cover Lenses.....	14
6.2	Fuses	14
6.3	Timing Belt	14
6.4	Mercotac rotary electrical connector	14
6.5	Lamp Ballast	15
6.6	Motor and Gearhead	15
7	Troubleshooting Chart, Replacement Parts and Wiring Diagrams.....	17

1 Introduction

1.1 About this Manual

The information in this manual is provided to assist installation and maintenance personnel in the proper installation, upkeep, and maintenance of the HBM 150/2 Airport Rotating Beacon. This manual also includes installation and maintenance instructions for all equipment sold as options to the basic unit.

1.2 Model Configurations

L801A1116: 120 VAC, 60 Hz, Class I (-30°C to +55°C)

L801A1125: 220-240 VAC, 50 Hz, Class I (-30°C to +55°C)

L801A1126: 220-240 VAC, 60 Hz, Class I (-30°C to +55°C)

L801A1216: 120 VAC, 60 Hz, Class II (-55°C to +55°C)

L801A1225: 220-240 VAC, 50 Hz, Class II (-55°C to +55°C)

L801A1226: 220-240 VAC, 60 Hz, Class II (-55°C to +55°C)

1.3 Warranty

Hali-Brite® products are guaranteed against mechanical, electrical, and physical defects (excluding lamps) for a period of one year from the date of installation or a maximum of two years from the date of shipment and are guaranteed to be merchantable and fit for the ordinary purposes for which such products are made. Hali-Brite® will correct by repair or replacement, at its option, equipment or parts which fail because of mechanical, electrical or physical defects, provided that the goods have been properly handled and stored prior to installation, properly installed and properly operated after installation, and provided further that Buyer gives Hali-Brite® written notice of such defects after delivery of the goods to Buyer. Hali-Brite® reserves the right to examine goods upon which a claim is made. Said goods must be presented in the same condition as when the defect therein was discovered. Hali-Brite® further reserves the right to require the return of such goods to establish any claim. Hali-Brite's obligation under this guarantee is limited to making repair or replacement within a reasonable time after receipt of such written notice and does not include any other costs such as the cost of removal of defective part, installation of repaired product, labor or consequential damages of any kind, the exclusive remedy being to require such new parts to be furnished. Hali-Brite's liability under no circumstances will exceed the contract price of goods claimed to be defective. Any returns under this guarantee are to be on a transportation charges prepaid basis. For products not manufactured by, but sold by Hali-Brite®, warranty is limited to that extended by the original manufacturer. This is Hali-Brite's sole guarantee and warranty with respect to the goods; there are no express warranties or warranties of fitness for any particular purpose or any implied warranties of fitness for any particular purpose or any implied warranties other than those made expressly herein. All

such warranties being expressly disclaimed. Details and values given in this manual are average values and have been compiled with care. They are not binding, however, and Hali-Brite® disclaims any liability for damages or detriments suffered as a result of reliance on the information given herein or the use of products, processes or equipment to which this manual refers. No warranty is made that the use of the information or of the products, processes or equipment to which this manual refers will not infringe any third party's patents or rights. The information given does not release the buyers from making their own experiments and tests.

1.4 Disclaimers

This manual is published for informational purposes only and the information provided should not be considered as all-inclusive or covering all contingencies. If further information is required, Hali-Brite® Inc. should be contacted. Sale of the product shown in this manual is subject to Hali-Brite's terms and conditions including, but not limited to, the Hali-Brite® Warranty. Such terms and conditions are available upon request. Hali-Brite's warranty will not apply to any products which have been "so repaired or altered outside the manufacturer's plants as, in the manufacturer's judgment, to affect its reliability and performance."

No warranties, express or implied, including warranties of fitness for a particular purpose or merchantability, or warranties arising from course or dealing or usage of trade, are made regarding the information, recommendations, and descriptions contained herein. The manufacturer is not responsible and will not be held liable in contract or in tort (including negligence) for any special, indirect or consequential damages, including injury or damage caused to vehicles, contents or persons, by reason of the installation of any Hali-Brite® product or its mechanical or electrical failure.

2 Safety Precautions

To help you install and maintain this equipment safely and efficiently make sure you read and understand all safety information in this manual prior to performing any procedure. Failure to do so may result in personal injury, property damage, or possible death.

2.1 Safety Statements

The following safety statements are used throughout this manual. They will alert you to possible safety hazards and conditions that could result in personal injury, death, or property and equipment damage.

CAUTION: Indicates hazards or unsafe practices that could result in minor personal injury, product, or property damage.

WARNING: Indicates hazards or unsafe practices that could result in severe personal injury or death.

DANGER: Indicates immediate hazards that will result in severe personal injury or death.

2.2 General Practices

Read and become familiar with the general safety instructions provided in this section of the manual before installing, operating, maintaining, or repairing this equipment.

- Do not attempt to assemble or install this equipment if it has been damaged from shipping.
- Do not attempt to install or maintain this equipment if you or the equipment is standing in water.
- Only qualified personnel should perform maintenance on this equipment.
- Always use proper tools (as mentioned in this manual) to perform installation and maintenance.
- Use proper hand and eye protection as needed when installing or maintaining this equipment.
- Make sure you have adequate first aid supplies available when installing this equipment.

- Do not modify this equipment as this could create a safety hazard and void your Hali-Brite® warranty.
- Use only Hali-Brite® replacement parts.
- Read and carefully follow the instructions given throughout this manual for performing specific tasks and working with specific equipment.
- Follow all applicable safety procedures required by your company, industry standards, and government or other regulatory agencies.
- Make sure all equipment is rated and approved for the environment in which you are using it.
- Follow all instructions for installing components and accessories.
- Protect components from damage, wear, and harsh environment conditions.
- Allow ample room for maintenance, wiring accessibility, and cover removal.

2.3 Electrical Practices

- Do not attempt to make electrical connections with the power on.
- Disconnect and lock out electrical power before touching any electrical connections.
- Install all electrical connections to local code.
- Use only electrical wire of sufficient gauge and insulation to handle the rated current demand. All wiring must meet local codes.
- Route electrical wiring along a protected path. Make sure moving equipment will not damage it.
- Protect equipment with safety devices as specified by applicable safety regulations.
- If safety devices must be removed for installation, install them immediately after the work is completed and check them for proper functioning.
- Always use rated electrical tools when performing electrical work.
- Always make sure electrical connections are tight.
- Make sure electrical covers are in place after installation.

- Do not touch hot lamps with bare hands.

2.4 Qualified Personnel

Qualified personnel are those that are trained and experienced with installing or maintaining Hali-Brite® equipment. Only qualified personnel should install or maintain Hali-Brite® equipment and auxiliary features.

No one should:

- Attempt to install or perform maintenance on this or any Hali-Brite® equipment if they are physically impaired or under the influence of alcohol or non-prescription drugs.
- Maintain or install this equipment without correct training, supervision or experience in mechanical or electrical equipment.
- Attempt to maintain or install this equipment without the correct tools as specified in this manual.

2.5 Proper Usage

Always use this equipment as specified in this manual. Improper usage may result in serious personal injury, property damage, or possible death.

- Do not make any modifications that have not been recommended by Hali-Brite®.
- Do not use any replacement parts that are not purchased from Hali-Brite®.
- Hali-Brite® cannot be responsible for injuries or damages resulting from nonstandard, unintended applications of its equipment. This equipment is designed and intended only for the purpose described in this manual. Uses not described in this manual are considered unintended uses and may result in serious personal injury, death, or property damage.

3 Specifications

3.1 Electrical and Optical Specifications

FAA Type	L-801A
Input Voltage.....	120 or 220-240VAC, +/-10%, 50/60 Hz
Power Consumption.....	395W (Class I), 795W (Class II)
Lenses.....	One clear, one green
Lamps.....	150W Metal Halide, Pulse Start
Rated Average Lamp Life	12,000 hours
Beam Intensity	25,000 min. effective candelas from +1° to +2° vertical and from +8° to +10° vertical, 50,000 min. effective candelas from +2° to +8°
Rotation Speed	12 RPM (Produces 24 flashes per minute)

3.2 Physical Specifications

Dimensions	Height: 30 inches (762 mm)
.....	Width: 20 inches (508 mm)
Mounting Dimensions.....	Four ½ inch (12.7 mm) holes in a rectangular pattern: (4"x 16") (101.6 x 406.4 mm)
Product Weight.....	75 lb. (34 kg)
Shipping Weight	175 lb. (79.5 kg)

3.3 Environmental Specifications

Operating Temperature (Class I)	-30°C (-22°F) to +55°C (+131°F)
Operating Temperature (Class I)	-55°C (-67°F) to +55°C (+131°F)
Heater (Class II only).....	400W (heating element)
Turns On	Below 0°C (+32°F)
Humidity	0% to 100%
Altitude	Sea level to 10,000 feet (3000 m)
Wind.....	Velocities to 100 mph (161 km/h)

4 Installation

WARNING: Allow only qualified personnel to perform the following tasks. Observe and follow the safety instructions in this document and all other related documentation.

4.1 Unpacking

Handle equipment very carefully to prevent component damage. Note any exterior damage to the carton/crate that might lead to detection of equipment damage. Open the top of the carton/crate. Remove foam packing from the top of the box. Carefully lift the unit out of the box.

CAUTION: Do not lift the unit by the head. Failure to observe this warning may result in equipment damage.

Unpack the carton/crate upon receipt and check the contents and their condition. If you note any damage to any equipment, file a claim with the carrier immediately. The carrier may need to inspect the equipment.

4.2 Tools and Supplies Needed

Equipment Required But Not Supplied

Wrenches

Set of Screwdrivers

Set of Pliers

Voltmeter

Insulation Tester

Level

Lightning Rod

Ground Wire (for lightning rod)

Liquid Glass Cleaner

S0-3 Cable, AWG 12, liquid-tight conduit and connectors

4.3 Installation

The HBM 150/2 rotating beacon comes completely assembled except for installation of a customer-supplied AWG 12, S0-3 power cord.

4.3.1 Mounting

Open the front door on the cabinet. Inspect the interior to make sure all parts are tight and have not been loosened in shipment. Close the door and tighten the latches.

Determine the beacon mounting location, and drill four 1/2" holes in the platform, spaced as shown in Figure 1.

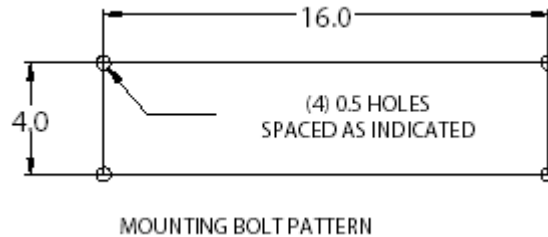

Figure 1

If the surface is not level, spacers or shims will be needed. Place a level on top of the weather cap and use shims as necessary under the four corners to bring the beacon to level. Install and tighten the mounting bolts, four each #1/2-13 bolts, length as required.

4.3.2 Wiring

See Figure 2 to locate the power connection point. The power cord enters the beacon chassis through the hole in the base, and attaches to the white terminal block in the lower right corner.



Figure 2

To install power cord, perform the following procedure:

1. Unscrew the two door latches and open the chassis door.
2. Route the cable through the hole in the bottom of the chassis. Install a ½" liquid-tight conduit fitting in the chassis hole.
3. Connect the power cord at the terminal strip as follows: Attach the black wire (120 VAC) to the terminal marked Ø, the white wire (neutral) to the terminal marked **N**, and the green wire (ground) to the terminal marked **G**.

4.3.3 Optional Heater Wiring

The optional heater assembly consists of a 400-watt heating element and thermostat. The heater assembly should be connected through a power cord to a separate circuit breaker, so that it may remain operable when the beacon is turned off. The circuit breaker should be switched off during the summer months. When the temperature drops below +32°F (0°C), the thermostat activates the heater, which is attached to the motor gearbox. The gearbox lubricant is warmed and this facilitates rotation of the beacon when it is energized.

The power connections for the heater are located on the same terminal block as the main beacon power connections. Attach the black wire (120 VAC) to the terminal marked Ø**C**, the white wire (neutral) to the terminal marked **N**, and the green wire (ground) to the terminal marked **G**.

4.3.4 Beam Angle Adjustment

All beacons are shipped from the factory preset at an elevation angle of 5 degrees, per FAA requirements. To adjust to a different angle, refer to Section 5.2.2.

5 Maintenance

5.1 Maintenance Schedule

<u>Interval</u>	<u>Task</u>
Daily	Inspect for lamp failure and proper rotation.
Bi-monthly	Inspect cleanliness of glass. Clean as necessary.
Annually	Inspect all electrical connections. Replace beacon lamps at 12,000 hours.

5.2 Maintenance Procedures

5.2.1 Lamp Replacement

WARNING: The lens temperature can be as high as 373 °F (189 °C). Allow one-half hour for the lamps to cool before opening the lens cover. Failure to observe this warning may result in personal injury or equipment damage.

1. Disconnect and lock out power to the beacon.
2. The beacon head cover has either (a) one screw and a hinge, or (b) two screws. Loosen the head cover screw(s) located at the edge of the head cover, and open or remove the head cover.
3. Remove the lamp by pulling it straight out of the socket.
4. Clean the reflector with glass cleaner.
5. Clean the new lamp with glass cleaner. After cleaning, do not touch the glass with your fingers.
6. Install the lamp by pushing it straight into the socket. Take care not to rub the edge of the reflector.
7. Close or replace the head cover, and tighten the screw(s).
8. Repeat as necessary for the other head.

5.2.2 Beam Angle Adjustment

All beacons are shipped from the factory preset at an elevation angle of 5 degrees, per FAA requirements.

To adjust the beacon beam to a different angle, perform the following procedure:

1. The beacon head cover has either (a) one screw and a hinge, or (b) two screws. Loosen the head cover screw(s) located at the edge of the head cover, and open or remove the head cover.

2. Locate the beam elevation label on the top inside edge of the head, near the edge of the reflector.
3. Loosen the two #10 Phillips-head screws located at the left and right outside edge of the head. Do not loosen them more than 2 turns.
4. Loosen the #10 Phillips-head screw located at the top outside edge of the head, directly above the beam elevation label. Do not loosen it more than 2 turns.
5. The beam angle may now be adjusted by gently pressing on the top and bottom edges of the reflector. Adjust the reflector until the pointer indicates the desired elevation on the elevation label.
6. Tighten the #10 Phillips-head screw located at the top outside edge of the head.
7. Tighten the two #10 Phillips-head screws located at the left and right outside edges of the head.
8. Close or replace the head cover, and tighten the screw(s).
9. Repeat Steps 1-8 for the other head.

5.2.3 Lens Cleaning

Clean lenses periodically with alcohol or glass cleaner and soft cloth. Wipe dry with a clean soft cloth.

5.2.4 Lubrication

All moving parts are permanently lubricated and will not require further attention.

6 Repair

6.1 Cover Lenses

Cover lenses are replaced as follows:

1. Locate the four metal clips located at the edges of the lens.
2. Remove the screw from each of the four clips.
3. Lift the lens out of the head cover.
4. Install the new lens in the head cover.
5. Install the four metal clips at the edges of the lens.

6.2 Fuses

The HBM 150/2 has a lamp fuse, and a motor fuse. The fuses are located on the Control Panel, directly inside the door of the chassis.

6.3 Timing Belt

To replace the timing belt:

1. Disconnect and lock out power to the beacon.
2. Disconnect the two lamp wires from the control panel. Refer to Section 7 for the wiring diagram.
3. Loosen the four screws on the motor, with a 5/32" Allen wrench and 3/8" wrench.
4. Slide the motor to the right and remove the old belt.
5. Install the new belt.
6. Tighten the belt by sliding the motor to the left. The belt should have 1/8" deflection. Do not over tighten the belt.
7. Reconnect the two lamp wires to the control panel.
8. Reconnect power to the beacon.

6.4 Mercotac rotary electrical connector

Perform the following steps to replace the mercotac rotary electrical connector:

1. Disconnect and lock out power to the beacon.
2. Disconnect the two lamp wires from the control panel. Refer to Section 7 for the wiring diagram.
3. Remove the two wires from the bottom of the coupling.
4. Loosen the cap screw in torque arm, and remove the torque arm.
5. Loosen the setscrew in the bottom of the main shaft, and remove the mercotac rotary electrical connector.

6. Remove the two wires from the top of the mercotac rotary electrical connector.
7. Place the black wire on the center tab of the new mercotac rotary electrical connector, and place the white wire on the outer tab of the new mercotac rotary electrical connector.
8. Reinsert the mercotac rotary electrical connector in the shaft, and tighten the setscrew. (**NOTE:** Do not over tighten.)
9. Reinstall the torque arm, and tighten the cap screw. (**NOTE:** Do not over tighten.)
10. Place the black wire on the center tab of the mercotac rotary electrical connector, and the white wire on outer tab of the mercotac rotary electrical connector.
11. Connect the two wires to the control panel. Make sure they are connected to the original terminals. (**NOTE:** The black wire connects to the upper terminal, and white wire connects to the lower terminal.)
12. Reconnect power to the beacon.
13. The Mercotac rotary electrical connector contains a small amount of mercury. It should be returned to the manufacturer for recycling, using the form located at the back of this manual.

6.5 Lamp Ballast

To replace a lamp ballast, perform the following steps:

1. Disconnect and lock out power to beacon.
2. Open the cabinet door.
3. Refer to the wiring diagrams in Section 7 to locate the connections. Disconnect the ballast input power leads at the terminal block.
4. Remove the ballast output wires at the terminal block.
5. Remove the two ¼-20 bolts and nuts attaching the ballast assembly to the main shaft, and remove the old ballast.
6. Place the new ballast into position on the main shaft.
7. Replace the two ¼-20 bolts to attach the ballast assembly to the main shaft.
8. Reconnect the ballast input power wires to the terminal block. (**NOTE:** Black wire on terminal labeled Ø, and white wire on terminal labeled **N**.)
9. Reconnect the ballast output wires to the terminal block.
10. Reconnect the power to the beacon.

6.6 Motor and Gearhead

1. Disconnect and lock out power to the beacon.
2. Refer to the wiring diagrams in Section 7 for component connections.
3. Loosen the four cap screws that hold the motor in place, and slide the motor to the right.
4. Remove the timing belt.

5. Remove the setscrews in the motor gear, and remove the gear. (**NOTE:** There are two setscrews in each hole.)
6. Disconnect the motor black wire from control panel.
7. Disconnect the wires from the capacitor.
8. Remove the nuts from the four motor cap screws.
9. Remove the motor and gearbox.
10. If replacing only the motor, separate the old motor from the gearbox, and replace with the new motor.
11. If replacing only the gearbox, separate the gearbox from the motor, and replace with the new gearbox.
12. Install the new motor and gearbox back on to motor plate with the four cap screws and nuts.
 - a. (**NOTE 1:** Make sure the shaft of the gearbox is to the right.)
 - b. (**NOTE 2:** Make sure the wires of the motor are facing out.)
13. Reinstall the gear on the shaft of the gearbox, and tighten the setscrews.
14. Reinstall the belt on the two gears, and tighten the belt by sliding the motor to the left, and tighten the cap screws and nuts. (**NOTE:** Adjust the timing belt for no more than 1/8" deflection.)
15. Reconnect the wires to the motor capacitor. Red wire on the left side, and the two white wires on the right side.
16. Reconnect the black wire to the neutral on control panel.
17. Reconnect the power to the beacon.

7 Troubleshooting Chart, Replacement Parts and Wiring Diagrams

Beacon Troubleshooting Chart

This chart will help you to locate over 99% of beacon problems. Detailed repair procedures are located in chapter 6 of this manual.

If you are still unable to solve the problem, call Hali-Brite at 800-553-6269.

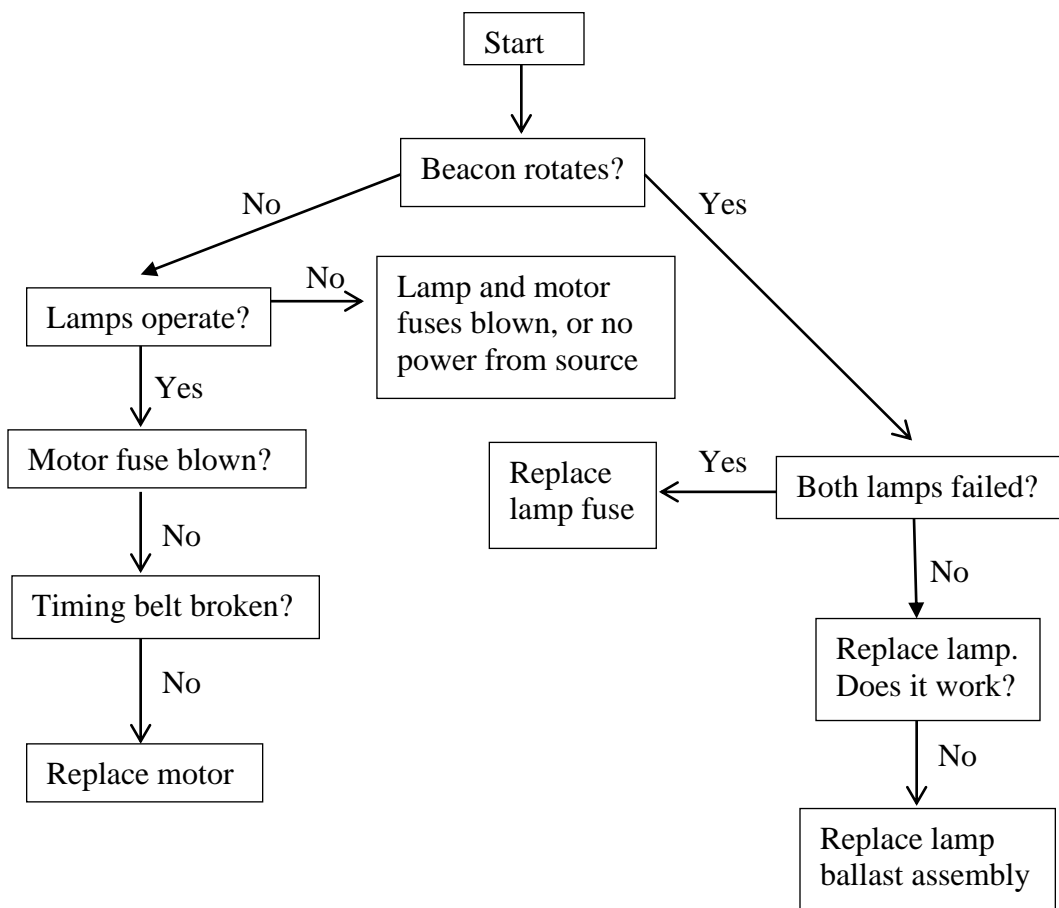

Replacement Parts

Ref	Part Number	Description
1	0200-0024	230VAC 50 Hz Ballast Assembly
2	0200-0023	120/240VAC 60 Hz Ballast Assembly
3	0600-0003	Timing Belt
4	2300-0002	Motor Fuse, 1/2 amp, 3AG, slow-blow
5	2300-0010	Lamp Fuse, 6.25 amp, 3AG, slow-blow
6	3400-0125B	Lamp, 150 watt pulse start, GE 20017
7	2800-0006	Lens, Clear
8	2800-0043	Lens, Green
9	1500-0011	Lens Clip
10	1800-0000	Mercotac rotary electrical connector
11	4100-0000-1A	HBM150 MOTOR

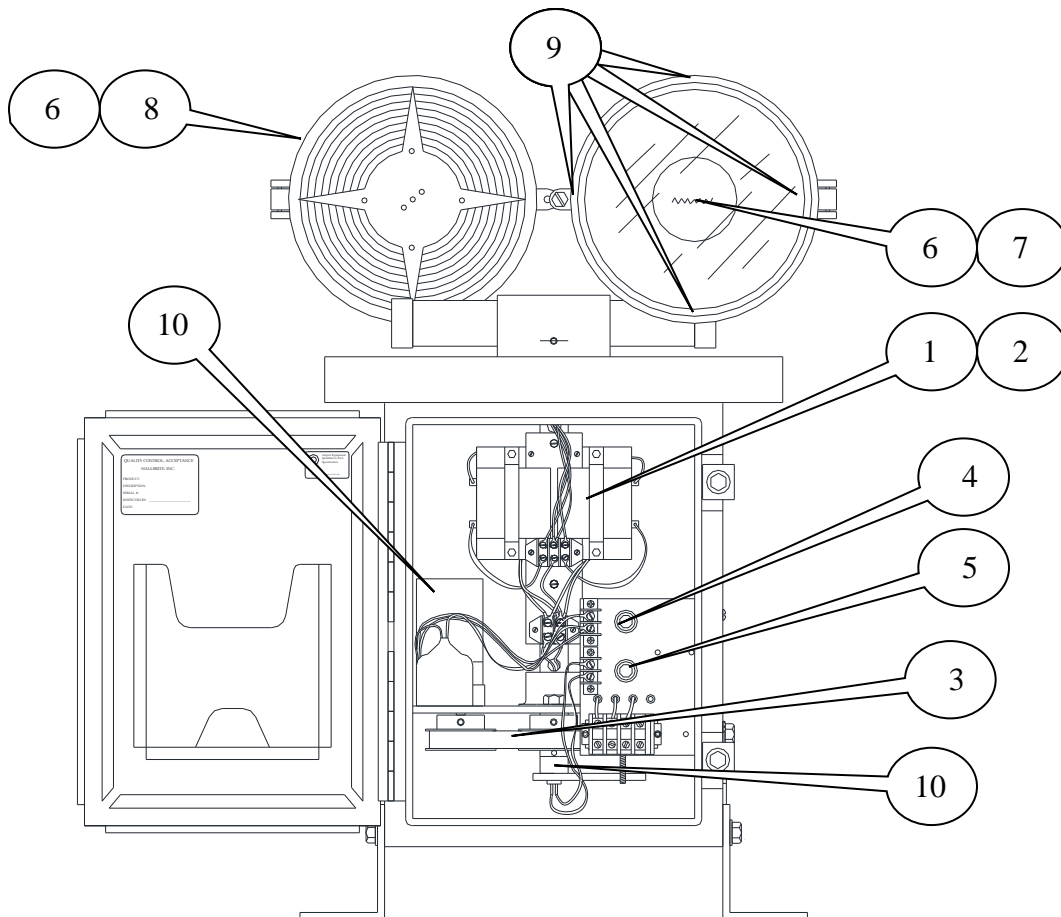

DIMENSION	TOLERANCE
X.XXX	+/- 0.005
X.XX	+/- 0.015
X.X	+/- 0.050
ANGLE	+/- 2°

REVISIONS				
ZONE	REV	DESCRIPTION	DATE	APPROVED
N/A	0	Original Release	3/4/04	N/A
N/A	1	Replaced Delta With MOVs	02/06/08	N/A
N/A	2	Remove Terminal Numbers	07/17/13	N/A

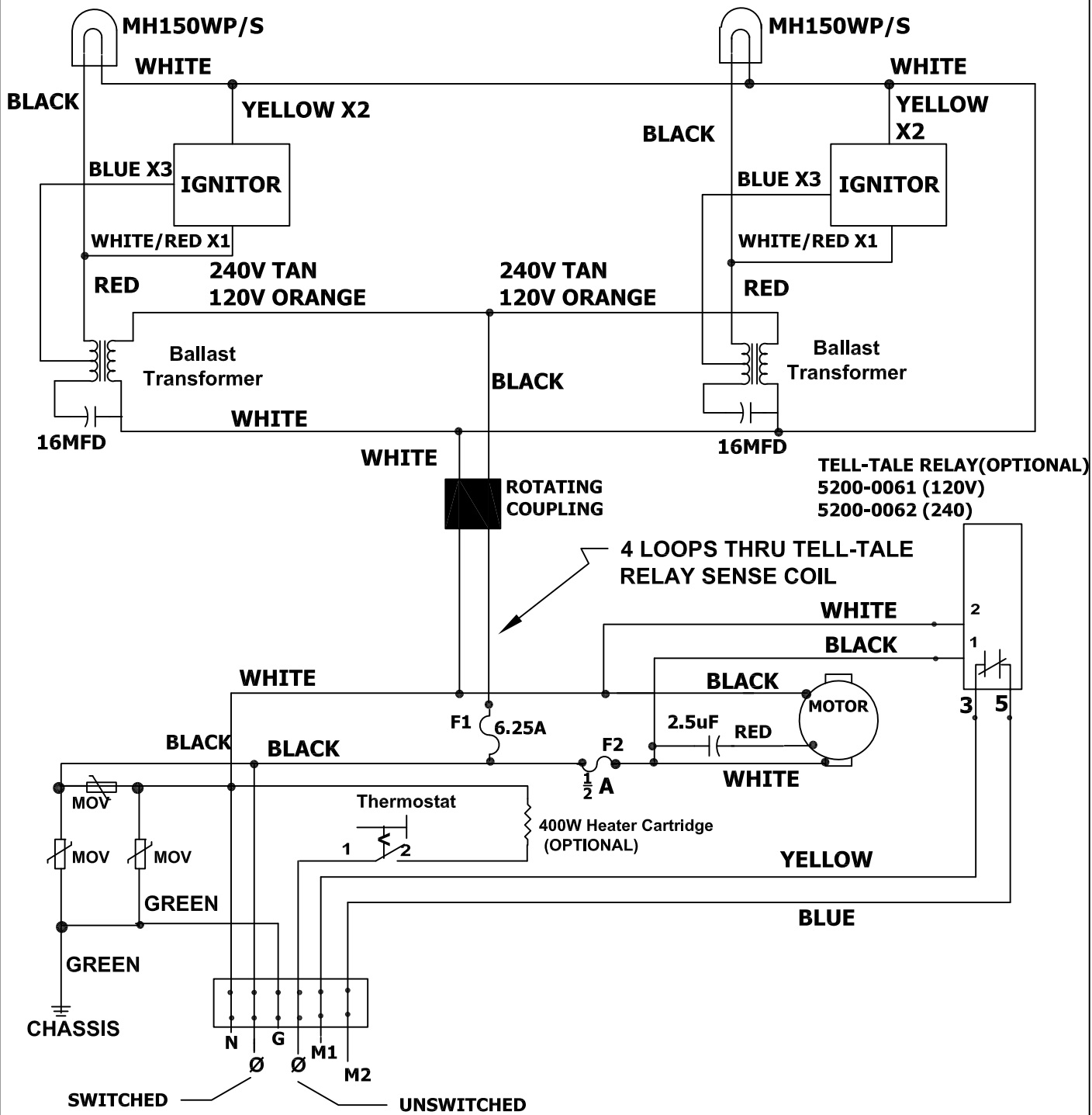

 HALI-BRITE, INC. P.O. Box 10 Crosby, MN 56441	FILE NAME: HB_2000_0012_R2		REV 2
	NAME: HBM 150/2 120/240V60HZ		
Drawn By: Lori Cross	SIZE A	FSCM NO. PART NO. 2000-0012	DATE 3/4/04
SCALE N/A		SHEET 1 OF 1	

DIMENSION	TOLERANCE	REVISIONS				
		ZONE	REV	DESCRIPTION	DATE	APPROVED
X.XXX	+/- 0.005	N/A	0	Original Release	3/4/04	N/A
X.XX	+/- 0.015	N/A	1	Added 2nd T/T Relay	10/20/05	N/A
X.X	+/- 0.050	N/A	2	Replaced Delta W/MOVS	02/06/08	N/A
ANGLE	+/- 2°	N/A	3	Added Second Relay Sense Location	10/06/09	N/A
		N/A	4	Added Loops Thru Relay	2/28/11	N/A

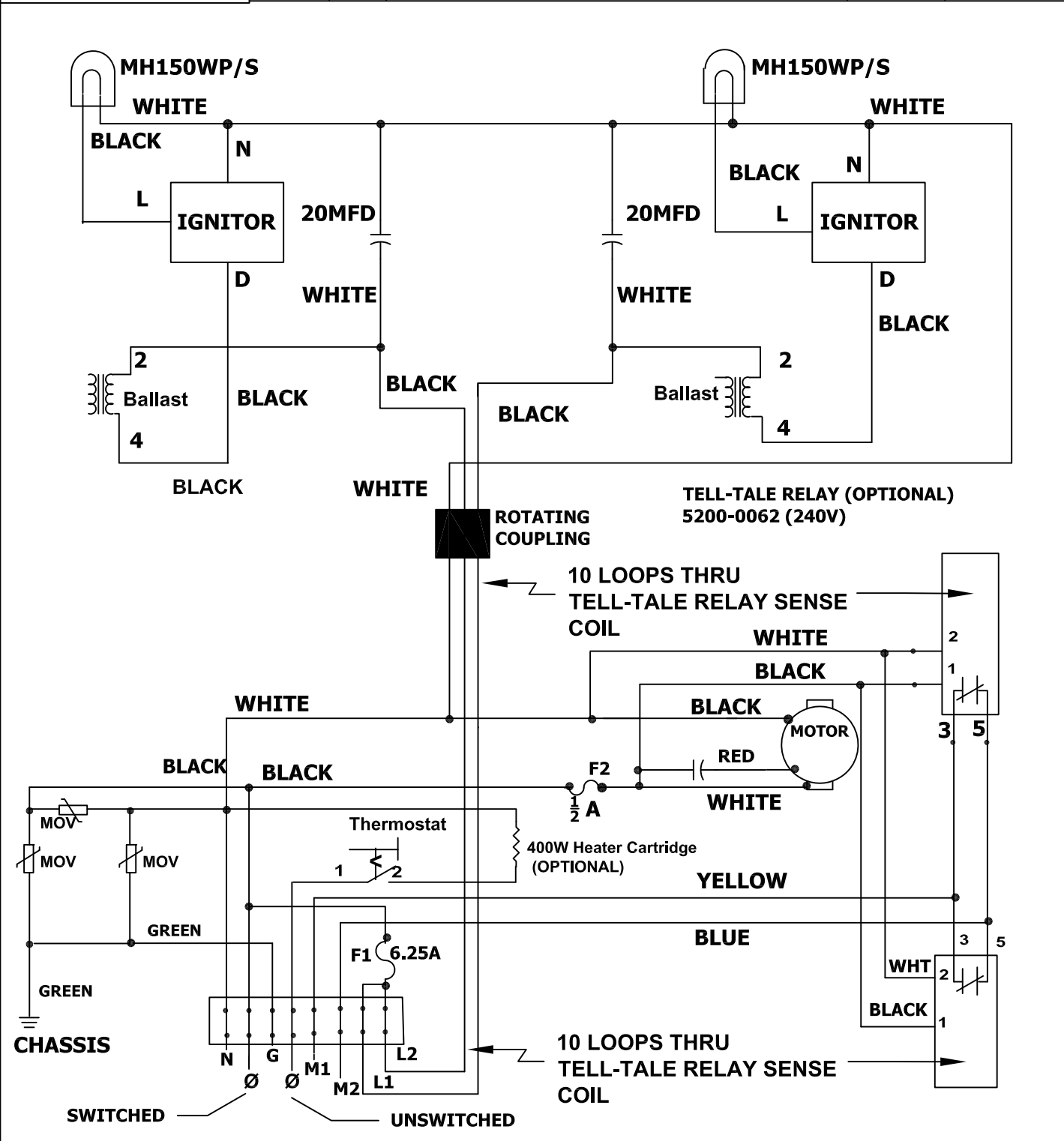

 HALI-BRITE, INC.	FILE NAME: HB_2000_0013_R4			
	NAME: HBM 150-2 240V50HZ			
P.O. Box 10 Crosby, MN 56441	SIZE A	FSCM NO.	PART NO. 2000-0013	REV 4
Drawn By: Lori Cross	SCALE N/A	DATE 3/4/04	SHEET 1 OF 1	

MERCOTAC CONNECTOR RECYCLING

Thank you for returning your used Mercotac connectors for recycling and not disposing them in the trash or landfill. The used connectors will be sent to a licensed mercury recycling facility where the liquid mercury is retrieved for future use through an environmentally safe distillation process.

HOW TO RETURN MERCOTAC CONNECTORS:

Used Mercotac connectors should be returned to Mercotac Inc. by UPS Ground shipping only. Do not send Mercotac connectors through the U.S. Mail. Mercotac Inc. provides free shipping within the 48 contiguous United States. Please contact Mercotac, Inc. for these shipping instructions. The used Mercotac connectors should be shipped to:

Mercotac Inc.
Attn: Returns
6195 Corte Del Cedro
Carlsbad, CA 92011

HOW TO PACKAGE:

The Mercotac connectors should be tightly sealed in a plastic bag using twist ties or a similar closure and then packaged with cushioning in a sturdy box. This completed Recycling Form must be included in the box with the shipment.

RETURNED CONNECTORS: (PACKING LIST)

<u>Model</u>	<u>QTY.</u>	<u>Model</u>	<u>QTY.</u>
_____	_____	_____	_____
_____	_____	_____	_____
_____	_____	_____	_____
_____	_____	_____	_____
_____	_____	_____	_____

FROM:

Company: _____

Contact: _____

Address: _____

Telephone #: _____

Do you require a receipt? Y N

Fax receipt to () _____

FOR MERCOTAC USE

Received by: _____

Date received: _____

Date Faxed: _____

- 1) Verify information on form and complete above.
- 2) Place used Mercotac connectors in Recycling container.
- 3) If required Fax receipt .
- 4) File completed form in Recycle File Folder,Engineering



6195 Corte Del Cedro, Carlsbad California 92011
Telephone (760) 431-7723 • Fax (760) 431- 0905
Email: info@mercotac.com