



Hali-Brite® RCM-LED UPGRADE for: L-893 Runway Closure Marker



Compliance with Standards:

FAA AC 150/5345-55 latest revision,
Engineering Brief 67, with FAA AC 150/5370-2 and
NTSB Safety Recommendation A-03-05

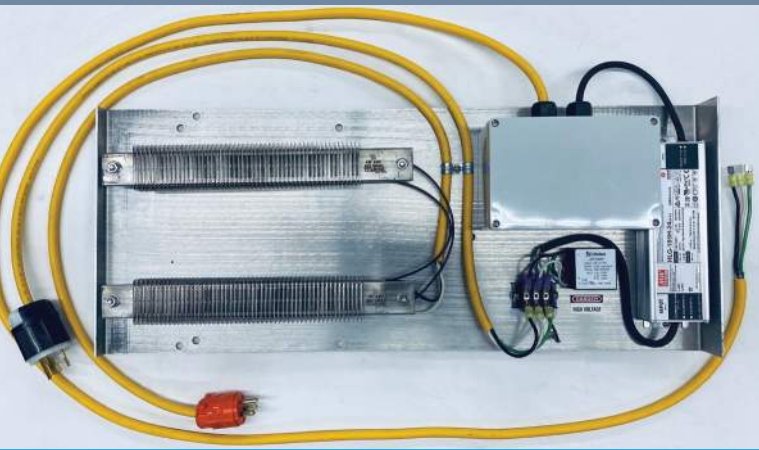

Features:

- Easily set up by one person in less than 5 minutes
- Four folding arms open to 14 foot length
- Hinged to generator housing, swings upright for use, swings to horizontal position when stowed
- Assembly arms fold to a 5'x5' square for transport and storage
- Arms constructed of 4"x4" extruded aluminum, with yellow epoxy powder-coat paint.
- 20 LED lamps mounted in front deliver over 70,000 candelas at beam center, plus 4 monitor lamps in rear, 24 total.
- Visible 10-25 miles from runway under VFR
- LED lamp, 20 degree beam width, rated life 50,000 hours typical
- Lamps flash 2.5 seconds on, 2.5 seconds off
- Solid-state flasher, no mechanical contacts
- Photocell automatically reduces intensity at night
- 2-year warranty on light assembly, 4 years on lamps
- Maximum Power: 630 watts, 643VA at 120VAC

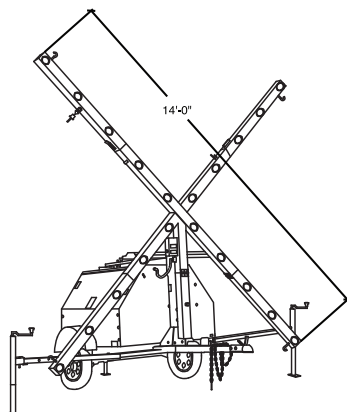

Sales and Technical Support:

1.800.553.6269
Sales@halibrite.com

📍 Hali-Brite, Inc.
1119 Madison Street
Brainerd, MN 56401

🌐 www.halibrite.com
☎ Ph: 218.454.0956
📠 Fax: 218.454.0972