

DIMENSION	TOLERANCE
X.XXX	+/- 0.005
X.XX	+/- 0.015
X.X	+/- 0.050
ANGLE	+/- 2°

ZONE		REV	DESCRIPTION	DATE	APPROVED
N/A		0	Original Release	10/12/20	N/A

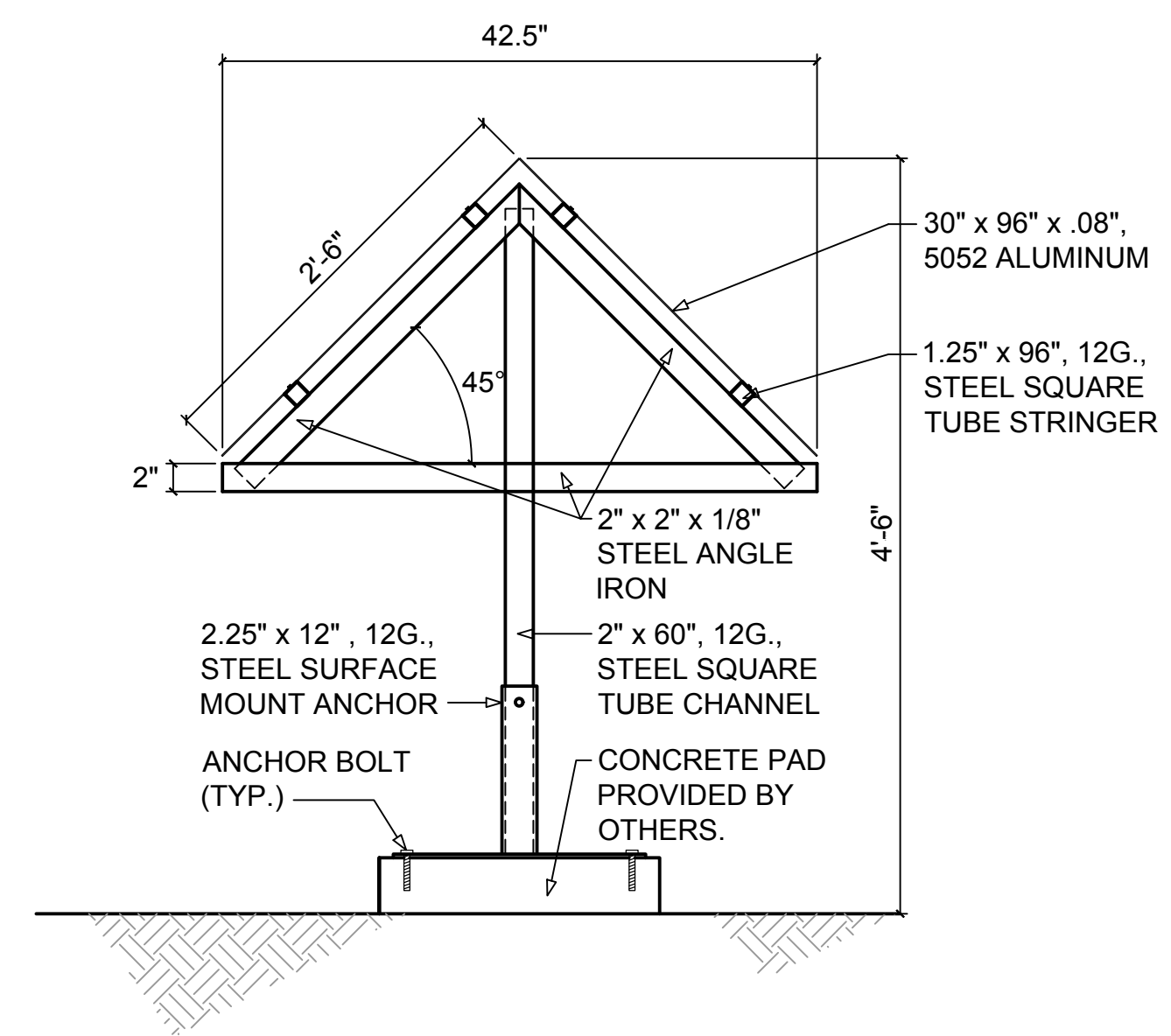

1 HB-5340 SEGMENTED CIRCLE SIDE VIEW
1" = 1'-0"

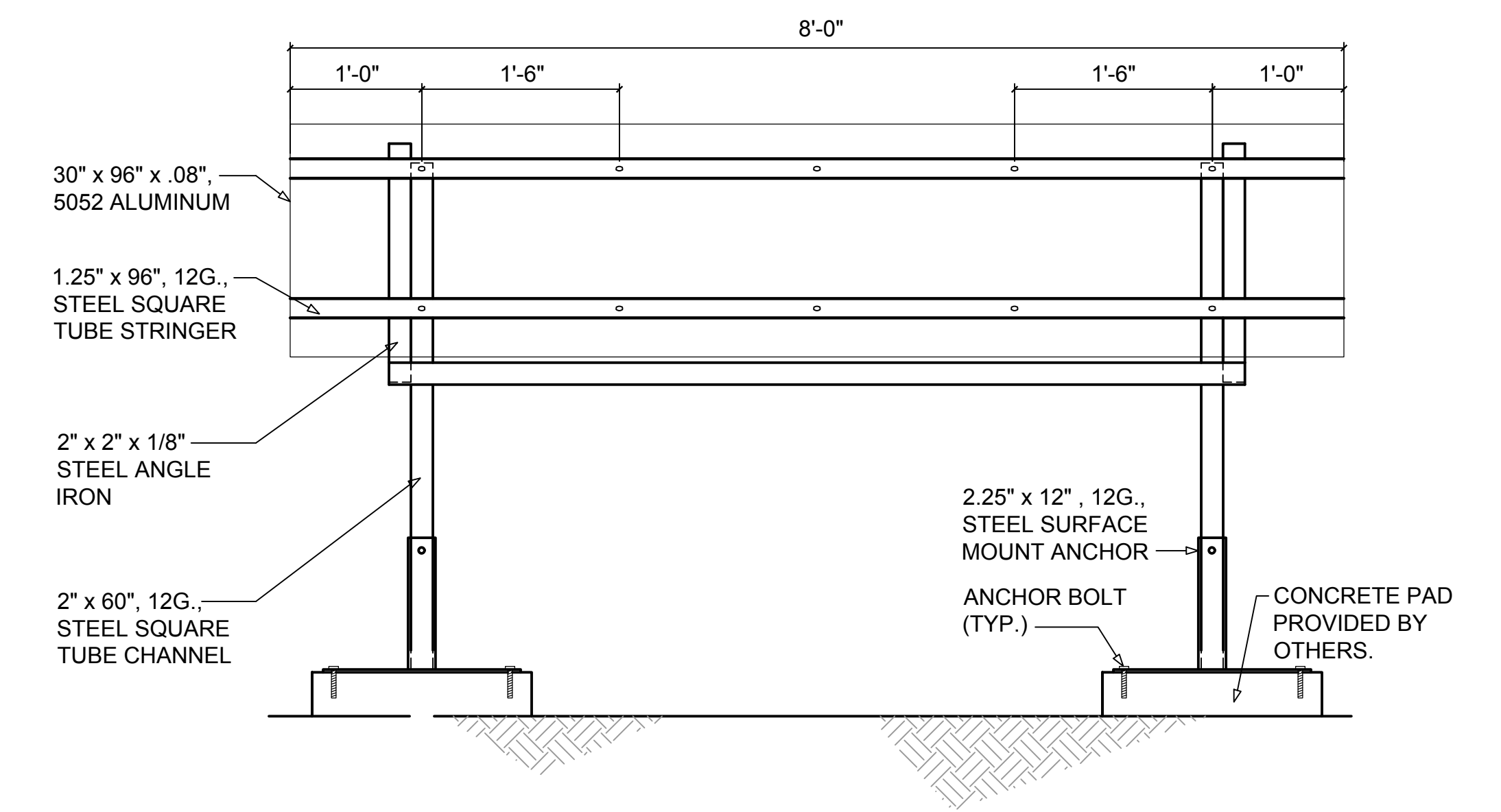

2 HB-5340 SEGMENTED CIRCLE FRONT VIEW
1" = 1'-0"

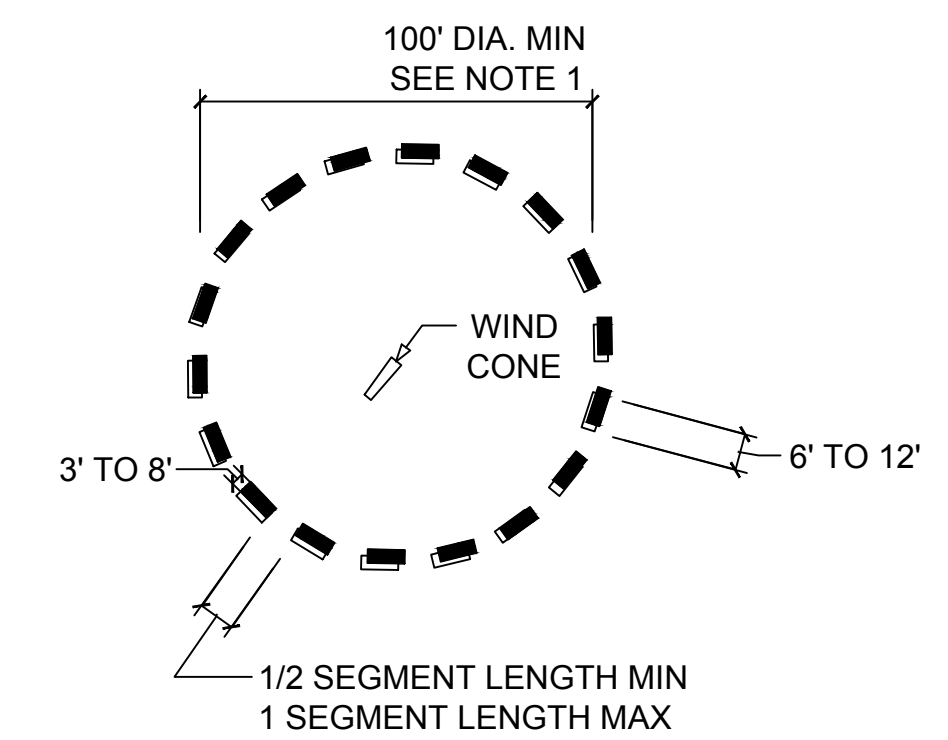

3 SEGMENTED CIRCLE MARKER AND WIND DIRECTION INDICATOR
1" = 1'-0"

 <p>Hali-Brite[®]</p> <p>1119 Madison St. Brainerd, Mn 56401</p> <p>Drawn By: Roger Wagner</p>	FILE NAME: SEGMENTED CIRCLE AIRPORT MARKER SYSTEM			
	NAME: HB-5340 Segmented Circle			
SIZE A	FSCM NO.	PART NO. 0100-3876	REV 0	
SCALE AS SHOWN	DATE 10/21/20	SHEET 1 OF 1		