



HBM 150/2 L-801 Airport Rotating Beacon

Features:

- FAA ETL Certified A/C150/5345-12 (Current Edition)
- ICAO Compliant ICAO: Annex 14, para 5.3.3
- Patented belt-drive system eliminates the lubrication required by conventional gear-drive beacons (U.S. Pat. 5,339,224)
- Patented liquid-filled lamp connector, eliminating the slip rings and brushes found on conventional beacons (U.S. Pat. 5,816,678)
- Two 14,000 lumen, 150 watt metal-halide lamps
- Typical lamp life (1-3 years)
- One clear lens, one aviation green lens
- NO maintenance except lamp replacement
- All moving parts are permanently lubricated
- Impedance-protected motor eliminates burnouts
- Lamps preset 5° above horizontal, adjustable
- 12 RPM rotation, 24 flashes/minute
- Weatherproof steel cabinet, powder coated international orange
- Optional stainless steel cabinet & bearings for highly corrosive environments
- Class I (No Heater) normal operating temperature range: 0°F to +131°F (-18°C to +55°C)
- Class 2 (With Heater) normal operating temperature range: -67°F to +131°F (-55°C to +55°C))
- Tested to wind velocities of 100 mph
- Optional tell-tale relay
- Mountable on a Hali-Brite Tipdown Pole
- Power Consumption: 395W Class I, 795W Class II
- Manufactured in the USA

Compliance with Standards:

FAA: L-801 A/C150/5345-12 (Current Edition)
ICAO: Annex 14, para 5.3.3

Applications:

L-801 Rotating Beacons are designed primarily for night operation as identification and location markers for airports.



Sales and Technical Support:

1.800.553.6269

Sales@halibrite.com

📍 Hali-Brite, Inc.
1119 Madison Street
Brainerd, MN 56401

🌐 www.halibrite.com
☎ Ph: 218.454.0956
📠 Fax: 218.454.0972

Optional Beacon Tipdown Pole



HBM 150/2 L-801 Airport Rotating Beacon

Ordering Information

Part Number	Description
L801A1116	120 VAC, 60 Hz, Class I
L801A1125	discontinued-replaced with LED model)
L801A1126	*220-240 VAC, 60 Hz, Class I
L801A1216	120 VAC, 60 Hz, Class II
L801A1225	discontinued-replaced with LED model)
L801A1226	*220-240 VAC, 60 Hz, Class II
*220-240v Models are for overseas applications, (220-240 volts LINE TO NEUTRAL)	

Options

Part Number	Description
L801/802 T/T HBM 120	Tell-Tale Relay 120V
L801/802 T/T HBM 240	Tell-Tale Relay 240V 60Hz
L801 HBM SS	For corrosive environment installations/ installations within 100mi of seawater: stainless steel cabinet, bearings, legs and hardware throughout.
4200-0000A	Tower Mounting Kit: Creates a platform from 36" Beacon to all current model beacons
4200-0001A	Tower Mounting Kit, Stainless Steel

Replacement Parts

Part Number	Description
0200-0007	Ballast, 120/240 VAC, 60 Hz
0600-0003	Belt
2300-0002	Motor Fuse, 1/2 amp
2300-0012	Lamp Fuse, 8 amp
3400-0125B	Lamp, 150 watt
2800-0006	Lens, Clear
2800-0043	Lens, Green
2800-0025	Lens, Amber
2800-0010	Lens, Red
2800-0026	Lens, Split Beam
1500-0011	Lens Clip

Shipping Information

Unpackaged Weight: 75 pounds
Shipping Weight: 110pounds
Shipping Volume: 48"x25"x25"

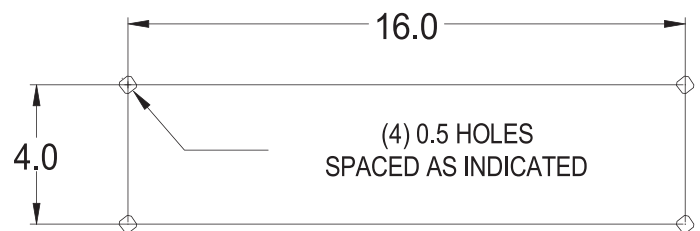
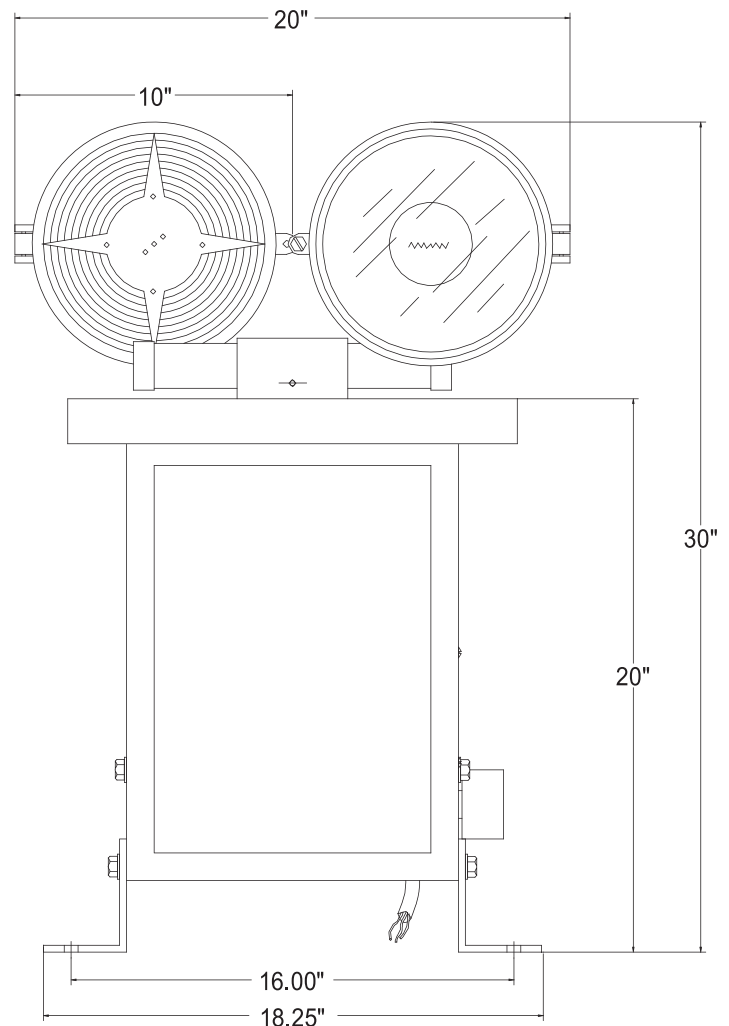

MOUNTING BOLT PATTERN

Sales and Technical Support:

1.800.553.6269

Sales@halibrite.com

Hali-Brite, Inc.
1119 Madison Street
Brainerd, MN 56401

www.halibrite.com
 Ph: 218.454.0956
 Fax: 218.454.0972