



**Compliance with Standards:**

FAA: L-802A A/C150/5345-12 (Current Edition)  
ICAO: Annex 14, para 5.3.3

**Applications:**

L-802A Rotating Beacons are designed primarily for night operation as identification and location markers for airports.



**Optional Beacon Tipdown Pole**

**Features:**



- FAA ETL Certified A/C150/5345-12 (Current Edition)
- ICAO Compliant ICAO: Annex 14, para 5.3.3
- Patented belt-drive system eliminates the lubrication maintenance required by conventional gear-drive beacons (U.S. Pat. 5,339,224)
- Patented liquid-filled lamp connector, eliminating the slip rings and brushes found on conventional beacons (U.S. Pat. 5,816,678)
- Two 40,000 lumen, 400 watt pulse-start metal-halide lamps
- Pulse-start lamps are fully bright in 3-5 minutes
- typical lamp life 2-4 years
- One clear lens, one aviation green lens
- NO maintenance except lamp replacement
- All moving parts are permanently lubricated
- Thermally-protected motor eliminates burnouts
- Lamps preset 5° above horizontal, adjustable
- 12 RPM rotation, 24 flashes/minute
- Weatherproof steel cabinet, powder coated international orange
- Optional stainless steel cabinet & bearings for highly corrosive environments
- Class I (No Heater) normal operating temperature range: 0°F to +131°F (-18°C to +55°C)
- Class 2 (With Heater) normal operating temperature range: -67°F to +131°F (-55°C to +55°C)
- Tested to wind velocities of 100 mph
- Optional tell-tale relay to monitor lamps and trigger a dry contact upon lamp outage
- Mountable on a Hali-Brite Tipdown Pole
- Power Consumption: 965W Class I, 1365W Class II
- Manufactured in the USA

**Sales and Technical Support:**

1.800.553.6269

Sales@halibrite.com

 Hali-Brite, Inc.  
1119 Madison Street  
Brainerd, MN 56401

 www.halibrite.com  
 Ph: 218.454.0956  
 Fax: 218.454.0972

## Ordering Information

Part Number	Description
L802A6116	120v, 60hz, Class I
L802A6125	discontinued- replaced with LED model
L802A6126	*220-240 VAC, 60 Hz, Class I
L802A6216	120v, 60hz, Class II
L802A6225	discontinued- replaced with LED model
L802A6226	*220-240 VAC, 60 Hz, Class II
*220-240v Models are for overseas applications, (220-240 volts LINE TO NEUTRAL)	

## Options

Part Number	Description
L801/802 T/T 120	Tell-Tale Relay 120V
L801/802 T/T 240	Tell-Tale Relay 240V 60Hz
L801 HBM SS	For corrosive environment installations/ installations within 100mi of seawater: stainless steel cabinet, bearings, legs and hardware throughout.
4200-0000A	Tower Mounting Kit: Creates a platform from 36" Beacon to all current model beacons
4200-0001A	Tower Mounting Kit, Stainless Steel

## Replacement Parts

Part Number	Description
0200-0021	Ballast Assembly, 60 Hz
0600-0003	Belt
2300-0003	Lamp Fuse, 10 amp
2300-0002	Motor Fuse, 1/2 amp
3400-0400/u/ed28/ps	Lamp, 400 watt
2800-0035	Lens, Clear
2800-0044	Lens, Green
0100-3825	Lens Clip

## Shipping Information

Unpackaged Weight: 150 pounds  
Shipping Weight: 220 pounds  
Shipping Volume: 48"x40"x33"

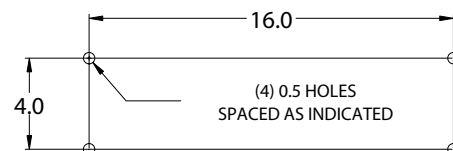
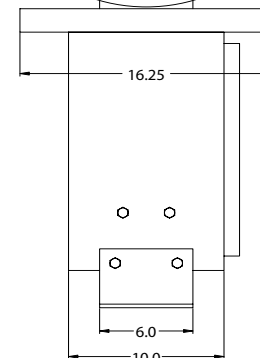
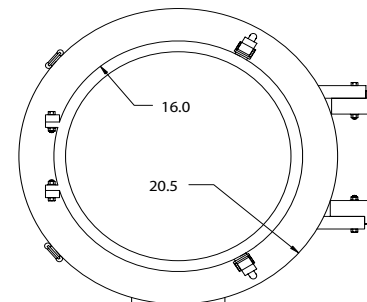
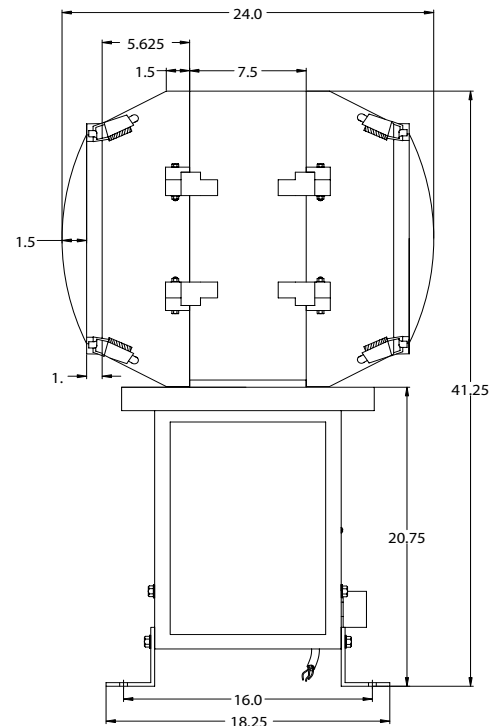





MOUNTING BOLT PATTERN

## Sales and Technical Support:

1.800.553.6269

Sales@halibrite.com

 Hali-Brite, Inc.  
1119 Madison Street  
Brainerd, MN 56401

 www.halibrite.com  
 Ph: 218.454.0956  
 Fax: 218.454.0972