



HBM 320 L-802M Military Airport Rotating Beacon



Compliance with Standards:

FAA: L-802M A/C 150/5345-12 (Current Edition)

Applications:

L-802M Rotating Beacons are designed for operation as identification and location markers for military airports.



Features:



- FAA Certified L-802M A/C 150/5345-12 (Current Edition)
- Patented belt-drive system eliminates the lubrication maintenance required by conventional gear-drive beacons (U.S. Pat. 5,339,224)
- Patented liquid-filled lamp connector, eliminating the slip rings and brushes found on conventional beacons (U.S. Pat. 5,816,678)
- Two 34,000 lumen, 320 watt pulse-start metal-halide lamps
- Pulse-start lamps are fully bright in 3-5 minutes
- typical lamp life 3-5 years
- One white dual-beam lens, one aviation green lens
- NO maintenance except lamp replacement
- All moving parts are permanently lubricated
- Thermally-protected motor eliminates burnouts
- Lamps preset 5° above horizontal, adjustable 2-10°
- 6 RPM rotation, 18 flashes/minute
- Weatherproof steel cabinet, powder coated international orange
- Optional stainless steel cabinet & bearings for highly corrosive environments
- Class I (No Heater) normal operating temperature range: 0°F to +131°F (-18°C to +55°C)
- Class 2 (With Heater) normal operating temperature range: -67°F to +131°F (-55°C to +55°C)
- Heater thermostatically controlled to engage at 0°F
- Certified to wind velocities of 100 mph
- Can operate with photocell and/or tell-tale relay
- Mountable on a Hali-Brite® Tipdown Pole
- Power Consumption: 793 W Class I, 1193 W Class II
- Manufactured in the USA

Sales and Technical Support:

1.800.553.6269

Sales@halibrite.com

 Hali-Brite, Inc.
1119 Madison Street
Brainerd, MN 56401

 www.halibrite.com
 Ph: 218.454.0956
 Fax: 218.454.0972

Beacon Tipdown Pole



HBM 320 L-802M Military Airport Rotating Beacon

Ordering Information

Part Number	Description
L802M6116	120v, 60hz, Class 1 (no heater)
L802M6125	*220-240v, 50hz, Class 1 (no heater)
L802M6126	*220-240v, 60hz, Class 1 (no heater)
L802M6216	120v, 60hz, Class 2 (with heater)
L802M6225	*220-240v, 50hz, Class 2 (with heater)
L802M6226	*220-240v, 60hz, Class 2 (with heater)

*220-240v Models are for overseas applications,
(220-240 volts LINE TO NEUTRAL)

Options

Part Number	Description
L801/802 T/T 120	Tell-Tale Relay 120V
L801/802 T/T 240	Tell-Tale Relay 240V 60Hz
L801 HBM SS	For corrosive environment installations/ installations within 100mi of seawater: stainless steel cabinet, bearings, legs and hardware throughout.
4200-0000A	Tower Mounting Kit: Creates a platform from 36" Beacon to all current model beacons
4200-0001A	Tower Mounting Kit, Stainless Steel

Replacement Parts

Part Number	Description
0200-0027	Ballast Assembly, 60 Hz
0600-0004	Belt
2300-0003	Lamp fuse, 10 amp
2300-0002	Motor fuse, 1/2 amp
3400-0136	Lamp, 320 watt pulse-start
2800-0056	Lens, aviation white
2800-0057	Lens, aviation green
0100-3825	Lens clip

Shipping Information

Unpackaged Weight: 155 pounds
Shipping Weight: 225 pounds
Shipping Volume: 48"x40"x33"

Sales and Technical Support:
1.800.553.6269
Sales@halibrite.com

Hali-Brite, Inc.
1119 Madison Street
Brainerd, MN 56401

www.halibrite.com
 Ph: 218.454.0956
 Fax: 218.454.0972

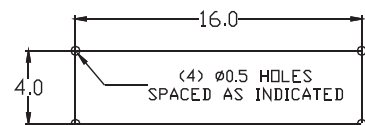
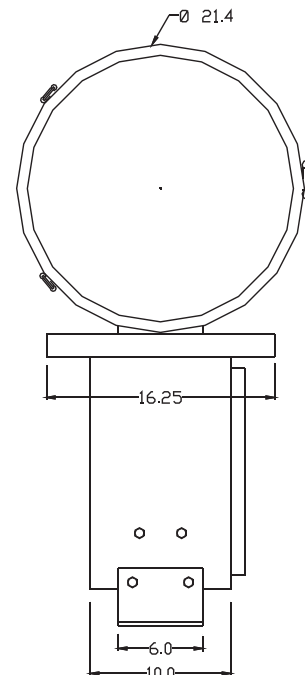
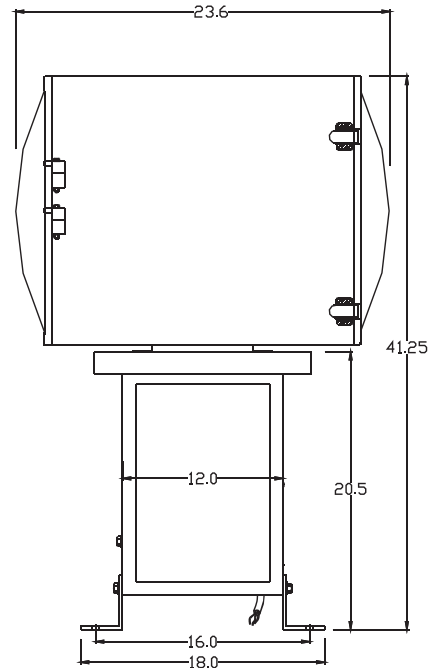

MOUNTING BOLT PATTERN