

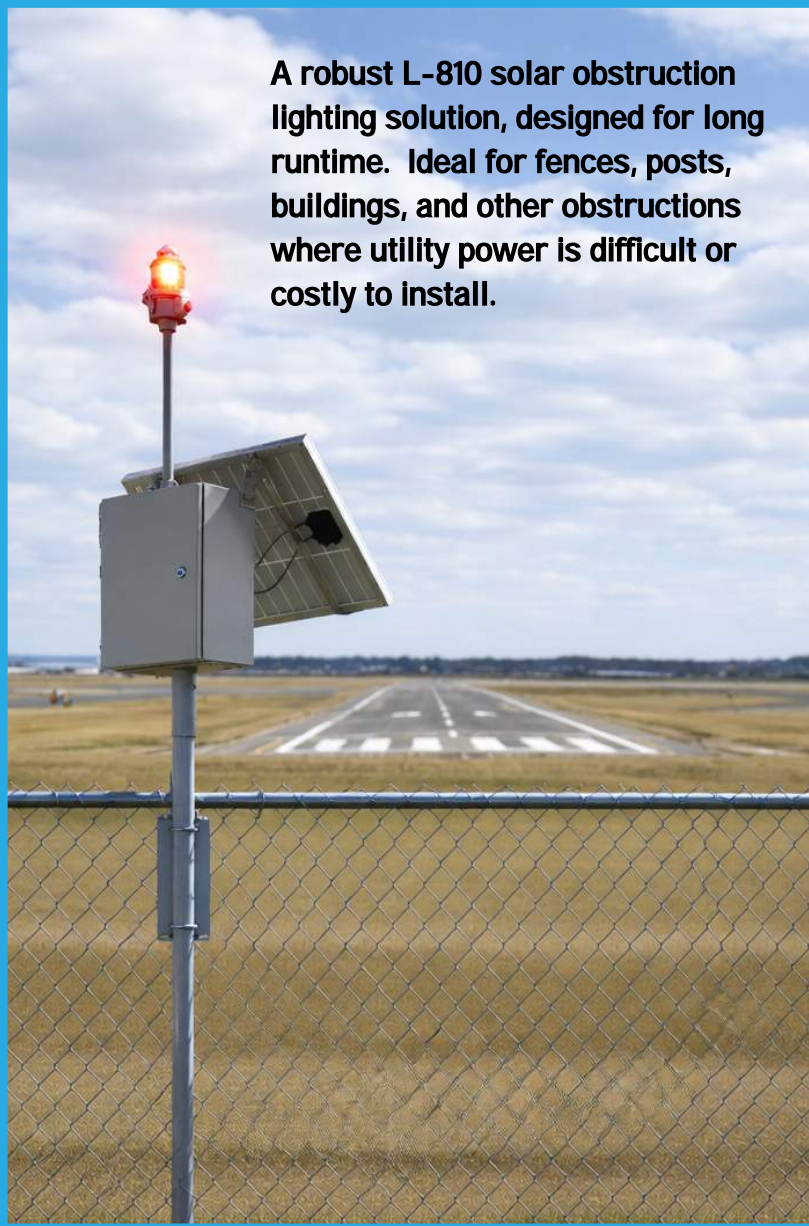

Hali-Brite® L810 Solar Powered Obstruction Light

A robust L-810 solar obstruction lighting solution, designed for long runtime. Ideal for fences, posts, buildings, and other obstructions where utility power is difficult or costly to install.



Installation/Operation Benefits

- No trenching or external electrical power required
- Designed for fast installation:
 - 1 person installation in ten minutes
 - Mount plate and post to fence first
 - Then slide on the pre-assembled enclosure and solar panel onto mount
- Universal fence-post mounting system included
- Wall-mount and roof-mount options for easy mounting to any building or other structure
- Zero energy costs

Certifications and Compliance

- FAA Engineering Brief 67 (EB67) compliant
- L-810 Obstruction Light Certified to FAA AC 150/5345-43J
- Wind Rating: 180 mph ultimate 3-second gust, Exposure C

Key Features

- Built for long runtime in any environment:
 - 50-watt solar panel for reliable operation in sunny and cloudy climates
 - High-capacity 50 Ah lithium-ion battery for extended service life and runtime
 - 7-day "no-sun" autonomy on a fully charged battery
- MPPT charge controller with bluetooth
- Automatic photocell for dusk-to-dawn operation
- Optional 24/7 "always on" mode
- Adjustable solar-panel angle to optimize performance by location
- Powder-coated for superior environmental protection





Hali-Brite® L810 Solar Powered Obstruction Light

Ordering Information

Part Number	Description
L810 SOLAR	Solar Power L810 With 50Ah lithium battery, MPPT charge controller, universal fence post mount and photocell (dusk to dawn)
L810 Dual Solar	Dual Solar Power L810 With 50Ah lithium battery, MPPT charge controller, universal fence post mount and photocell (dusk to dawn)
L810-RM	Roof mount flange
L810-WM	Wall mount bracket

Mounting Configurations

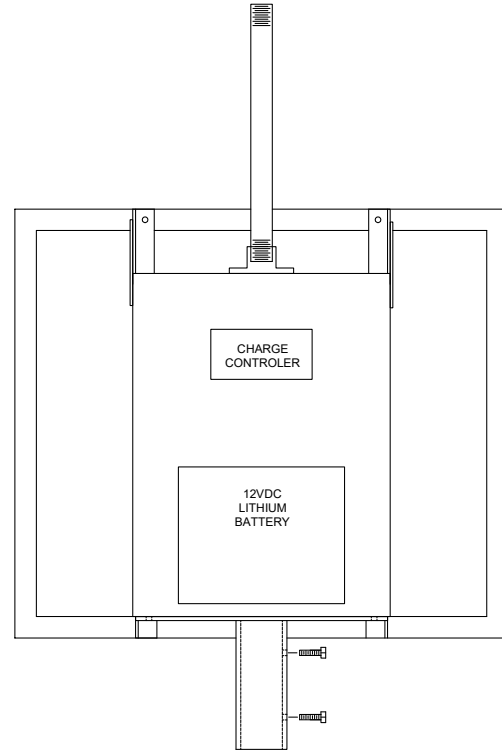

Shown with optional WALL MOUNT

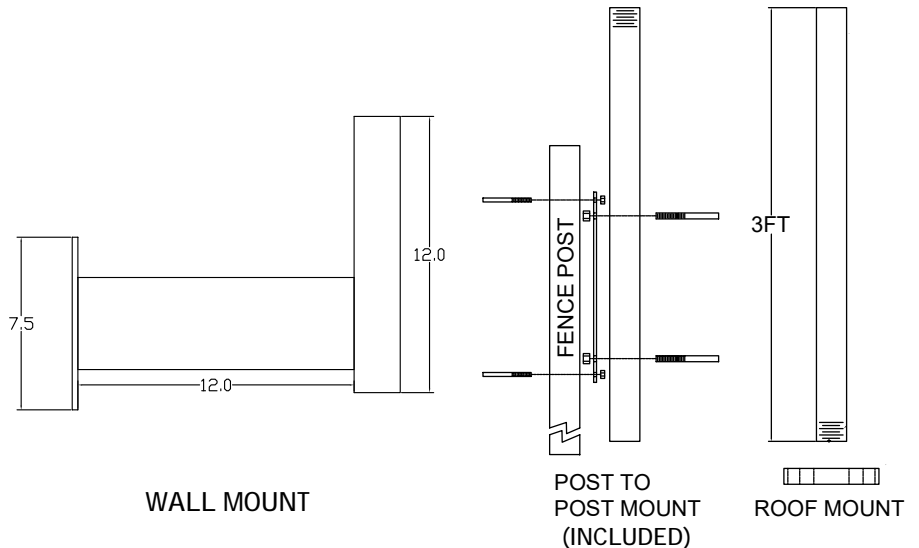

Shipping Information

Product Weight:
 Main enclosure, battery, and light 48.2 Lbs
 Fence mount hardware and post 10.2Lbs
 Shipping Dimensions: 36"x24"x20"
 Shipping Weight: 60Lbs

Sales and Technical Support:

1.800.553.6269
 Sales@halibrite.com

Hali-Brite, Inc.
 1119 Madison Street
 Brainerd, MN 56401

www.halibrite.com
 Ph: 218.454.0956
 Fax: 218.454.0972